

CUSTOM VALVE ORDER PRINT

PLEASE FILL IN ALL INFORMATION

- WITH HARDTIP
- WITHOUT HARDTIP

USE BLANK _____

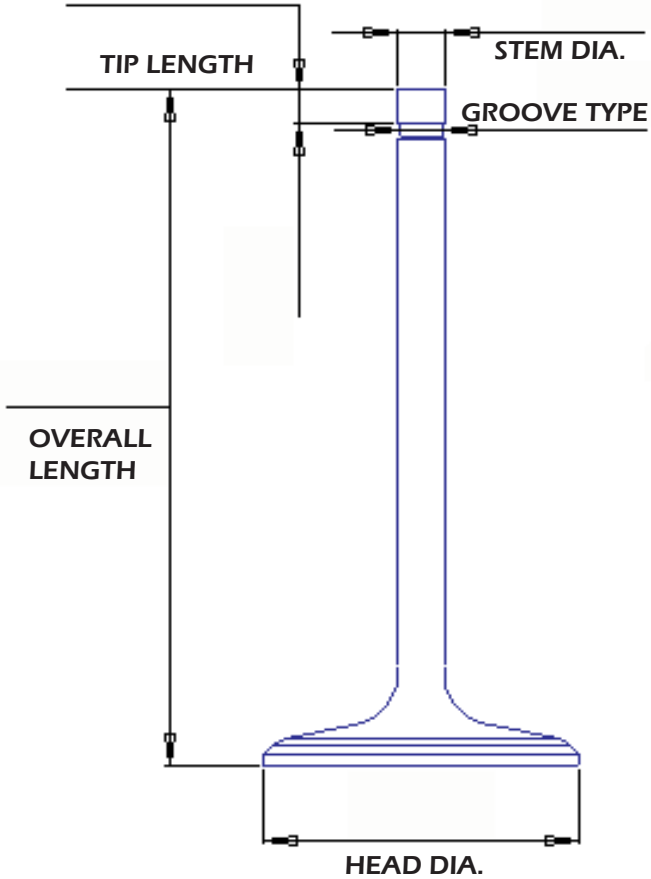

- CONVENTIONAL
- RADIUS LOCK
- RADIUS
- OTHER _____

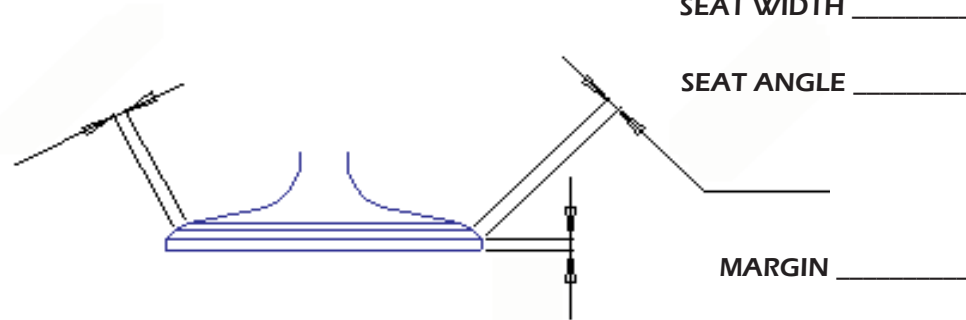

- SHARP
- BREAK
- CORNER RADIUS

CUSTOM ORDER INFORMATION

CUST. NAME _____

PHONE _____

ORDER DATE _____

QTY. _____

